



# 3JH40 Common Rail

Configuration	4-stroke, vertical, water-cooled diesel engine	
Maximum output at crankshaft*	29.4 kW@3000 rpm	[40 mhp@3000 rpm]
Displacement	1.642 L	[100 cu in]
Bore x stroke	88 mm x 90 mm	[3.46 in x 3.45 in]
Cylinders	3 in-line	
Combustion system	Direct injection with Bosch common rail system	
Low idle rpm	800 rpm	
Aspiration	Naturally aspirated	
Starting system	Electric starting 12V – 1.4 kW	
Alternator	Valeo 12V - 125A	
Cooling system	Fresh water cooling by centrifugal fresh water pump Seawater cooling by rubber impeller seawater pump	
Lubrication system	Enclosed, forced lubricating system	
Direction of rotation [crankshaft]	Counterclockwise viewed from stern	
Dry weight without gear**	192 kg	[423lbs]
Emission compliance	EU: RCD 2, BSO II, EMC	US: EPA Tier 3
Engine mounting	Rubber type flexible mounting	

**NOTE:**Fuel condition: Density at 15°C = 0.84 g/cm<sup>3</sup>; 1 kW = 1.3596 mhp = 1.3410 HP

\* Fuel temperature 40°C at the inlet of the fuel injection pump [ISO 8665: 2006]

\*\* Including damper disk

Technical data is according to ISO 8665: 2006

**DIMENSIONS**

Right side view

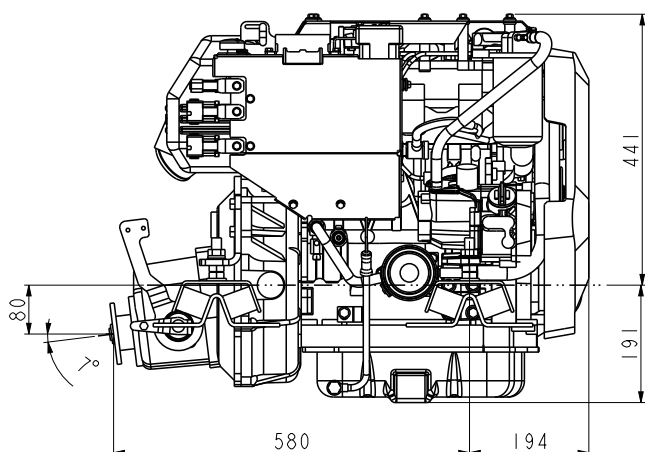

Rear view

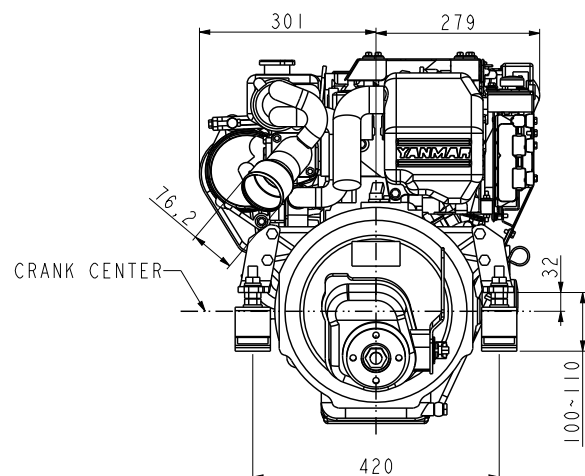

3JH40 with KMH35A marine gear



PERFORMANCE CURVES

3JH40 Torque curve

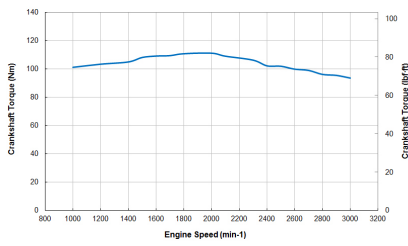

3JH40 Output Power curve

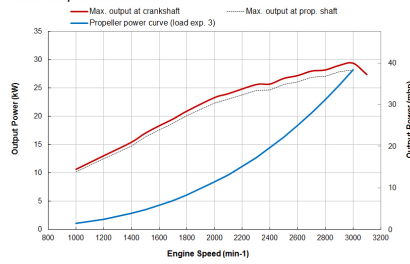

3JH40 Fuel consumption (propload exp 3.0)

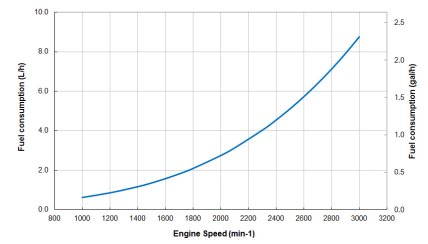

MARINE GEARS\*

Model	KM35P [parallel]		KM35A [down angle: 7°]		Saildrive SD60	
Type	Mechanical cone clutch		Mechanical cone clutch		Mechanical wet multi-disc clutch	
Dry Weight**	12 kg [26 lbs]		13 kg [29 lbs]		44 kg [97 lbs]	
Reduction Ratio [fwd/asn]	2.36/3.16	2.61/3.16	2.33/3.04	2.64/3.04	2.23/2.23	2.49/2.49
Propeller speed [fwd/asn]	1232/921	1114/921	1246/955	1103/955	1304/1304	1167/1167
Direction of rotation [viewed from stern]	Clockwise		Clockwise		Clockwise & counter clockwise	
Dry weight - engine & gear	204 kg [450 lbs]		205 kg [452 lbs]		236 kg [520 lbs]	
Length engine and gear/drive	776 mm [30.6 in]		774 mm [30.5 in]		705 mm [27.8 in]	

\*For other configurations, consult your local Yanmar distributor.

\*\*Dry weight includes cooler and brackets

INSTRUMENT PANELS

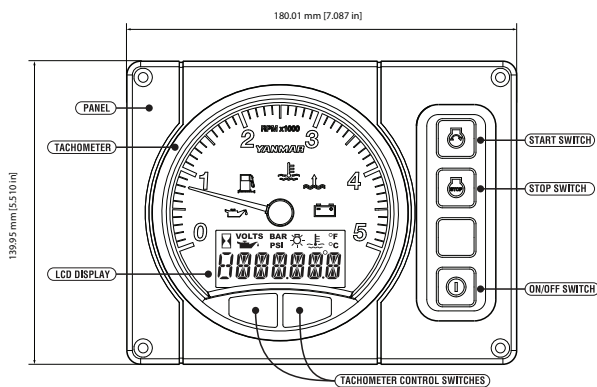

B25 STANDARD

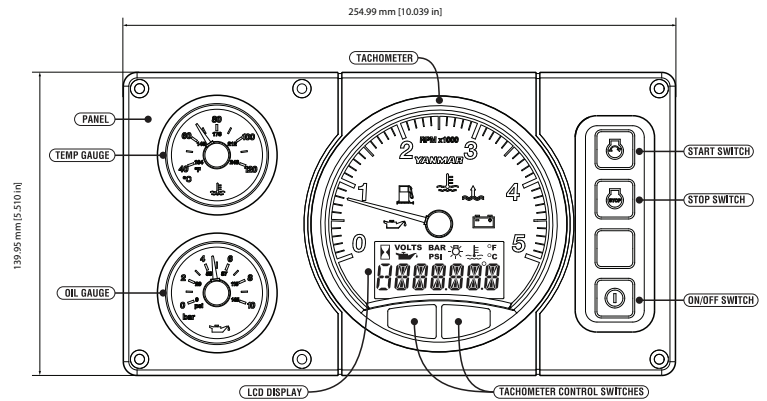

C35 OPTIONAL

ACCESSORIES

Standard Package

- Exhaust mixing elbow [L-type]
- Alternator 12V - 125A
- B25 panel
- Oil sensor for instrument panel
- Mechanical throttle sensor
- Set of flexible engine mounts
- Fuel pre-filter with water separator
- Fresh water expansion tank
- Belt safety cover
- Engine topcover for protection
- Operation manual

Optional

- High-riser mixing elbow [instead of L-elbow]
- Secondary alternator 12V - 125A or 24V - 60A
- Semi 2-pole
- Hot water kit with cocks
- Extension harness [3m, 5m, 10m]
- C35 panel
- VC10 Vessel Control System
- Second station
- NMEA2000 Engine monitoring system
- Propeller cone nut kit SD60
- Extension saildrive leg [75mm]

NOTE: All data subject to change without notice. Text and illustrations are not binding.